

DESCRIPTION

Thank you for purchasing the FSXC2 CUTTER from Malco. The FSXC2 CUTTER may be used by professionals to cut the vertical leg of mechanically seamed panels in the event the roof needs to be removed or repaired. Keep reading to learn more about how to setup and use the FSXC2 CUTTER.

SPECIFICATIONS

MAX. THICKNESS

- Steel: 24 ga. (0.7 mm)
- Stainless steel: 26 ga. (0.5 mm)
- Aluminum, Copper, Zinc: 20 ga. (0.8 mm)

MAX. SPEED

- 49 ft./min. (15 m / min)

DEVICE WEIGHT

- 12.5 lbs. (5.67 kg)

MAX. CUTTING DIMENSIONS

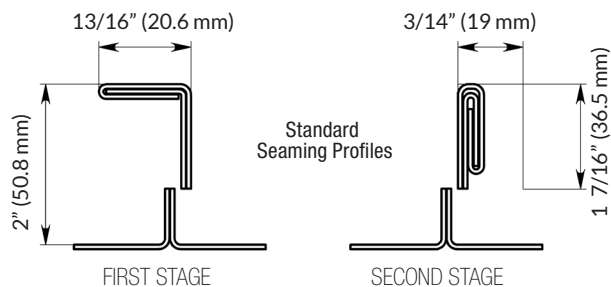

DRILL/DRIVER REQUIREMENTS

MAX. TORQUE

- 1325 in./lb.

RECOMMENDED TORQUE

- 975 in./lb.

MIN. TORQUE

- 535 in./lb. for soft roof material

! Do not use impact driver or hammer drill in hammer mode while operating this tool.

SET UP

! Always remove drills power source when setting up the FSXC2 CUTTER for your own safety!

1. Install drive shaft into drill chuck. Tighten the chuck. If using a keyless chuck we recommend tightening fully by hand then rotating the chuck back to lock the chuck if equipped.
2. Adjust and tighten support bar.
3. Stretch the bunjee cord around the drills/drivers' battery accordingly.
4. Set drill to drill mode, set drill speed to 1 (lowest RPM), then verify the drill is spinning clock wise, this will ensure the cutter moves in a forward direction.
5. You are all set up and ready to go. Please move on to the operation section.

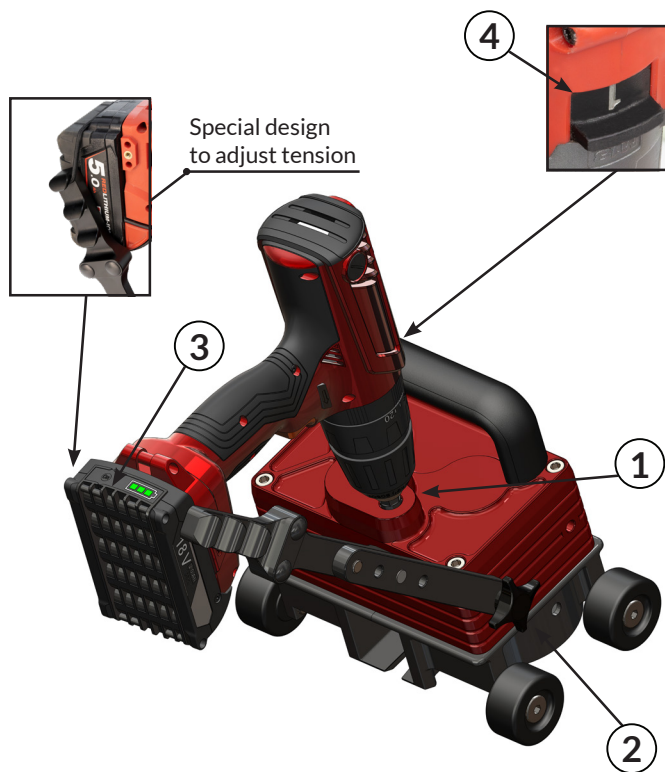

OPERATION

! Check whether material thickness and roof profile dimensions are within allowable range specified in this instruction.

TO CUT FULL LENGTH PROFILE

Before cutting the vertical leg, confirm the cutter is able to ride under the seamed profile as shown in the image below.

1. Expose both ends of the seam to ensure the FSXC2 CUTTER may operate over the full length of the seam.
2. Position the FSXC2 CUTTER at a seam end with the seam centered between the wheels.
3. With the drill set to speed 1, use the variable speed trigger to feed the cutter on to the seam. Once the cutter is feeding material correctly, fully depress the trigger and cut the seam off of the roofing material.

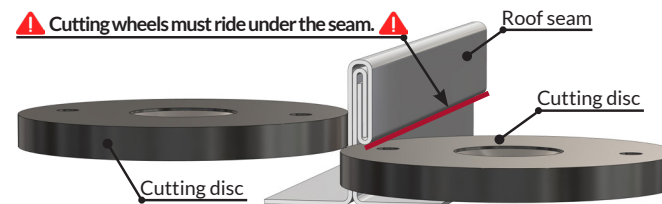

! Cutting wheels must ride under the seam. **!**

! Use correct cutting position! Machine is not designed to cut the middle of the seam continuously. It is only allowed for crossing the seam - going in and out. **Do not cut more than 4 layers of metal!**

TO CUT FROM THE MIDDLE OF THE PROFILE

The FSXC2 CUTTER may be started or stopped mid seam if required.

1. Center the cutter over the seam and tilt the cutting wheels down (20-30 degrees towards the direction you intend to cut.
2. Apply downward pressure towards the direction of cut and use the variable speed trigger to feed the material into the cutter. Once the seam has been cut, fully depress the trigger and cut the vertical leg as needed.

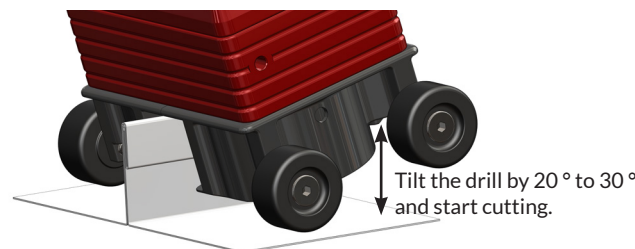

VIDEO INSTRUCTION



HEIGHT ADJUSTMENT

The FSXC2 CUTTER is height adjustable for 2" and 1.5" profiles. The cutting discs must be positioned under the seam, and all 4 wheels need to be set to the same height for best results.

1. Remove the wheels using the provided 5mm wrench.
2. Refasten the wheels in correct position.
3. Visually confirm the height of the cutting discs is correct for the seam height and that all 4 wheels are contacting the material.
4. Tighten the fasteners retaining the wheels.
5. You are all set up and ready to go. Please move on to the operation section.

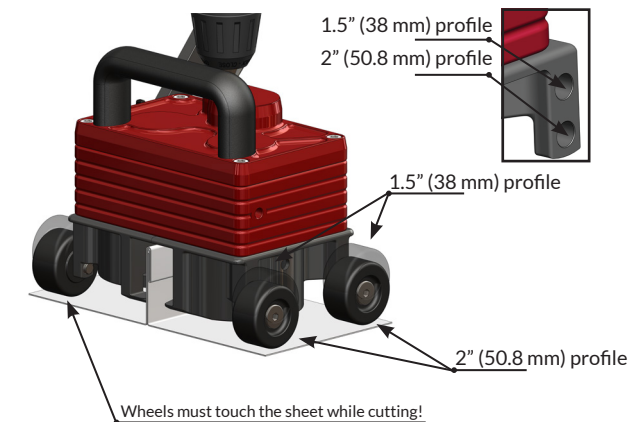

! All 4 wheels must be in the same height!

WARRANTY

- Malco Products warrants to the original customer/consumer that its products will be free from manufacturing defects in materials or workmanship when subject to normal and proper use.
- Should any such defect occur following original purchase, Malco Products will repair or replace, at its discretion, the defective product.
- Malco Products shall not be liable or responsible for labor charges or other expenses whatsoever in connection with removal or installation of either the original or replacement product. In the event of repair or replacement under the terms of this warranty, the original warranty shall apply to the repaired or replacement product.
- See full terms and conditions on our website.

MALCO ROOFING ESSENTIALS



Seamers



Modular Benders



2 Station Benders



Disc Benders

SAFETY INFORMATION

- Not recommended for cutting non-metals. Malco Products takes no responsibility for the safety of the attachment if it is used in any way other than the intended purpose as specified in the operating instructions.
- Only use cordless drills that meet the manufacturer requirements.
- Visually inspect components before installing on drill/driver. Do not use if cracked or broken.
- Be aware of rotating parts. Keep hands, fingers, hair, clothes, and other tools at a safe distance. Do not wear loose clothing or jewelry. Keep your hair, clothing, and gloves away from moving parts because they can be caught in moving parts.
- Avoid cutting point. Never place your hands and fingers between guards and cutting discs. It is strictly forbidden to remove guards.
- Make sure lighting is sufficient.
- Do not over-reach to perform cutting operation. Always use roof lifeline and follow all safety regulations.
- To prevent the tool from falling off the rooftop, settle tool steady on one side avoiding direct wheel contact with angular surfaces.
- Do not operate tool when you are tired or under the influence of drugs, alcohol, or medication. A moment of inattention while operating may result in serious personal injury
- Do not force cut. If the cutting discs becomes jammed, change driving direction and drive backwards out of the seam. Do not try to cut the jammed place - use scissors or other suitable tools.
- Keep any power cables away from cutting path, cutting discs, and any cut metal.
- Keep away from children.
- Always wear goggles or safety glasses.
- Wear protective gloves when operating and performing maintenance.
- Use hearing protection when operating.
- Do not let familiarity with product replace strict adherence to safety rules. Misuse may cause serious personal injury.
- It is strictly forbidden to install, dismantle, replace and modify components, parts and equipment not provided for in this manual without written agreement from the manufacturer.

CARE AND MAINTENANCE

- Store in the case when tool is not in use. Clean and dry tool after each use.
- Do not use tool under wet and moist conditions.
- Do not expose tool to extreme temperatures (below 0 degrees) and weather conditions.
- Always clean dirt, dust, sand, and other scrap from cutting discs, axles, and guards.
- Maintain tool using factory original replacement parts if the cutting discs, bolts, or guards show signs of wear.



DO NOT use case for any other purposes than caring and storing only Malco FSXC2 CUTTER. Do not put other tools - such as snips, pliers etc. in the case!

CUTTING DISC REPLACEMENT

Keep the cutting discs of the FSXC2 CUTTER sharp replace when necessary to ensure quality cutting performance.

1. Remove two 6 mm hex key screws.
2. Remove the cutting discs. If necessary, use M6 bolts to push out the blades.
3. Clean all the dirt and dust from guards and axles under the discs.
4. Place the new cutting discs.
5. Reassemble the screws and tighten the blades.

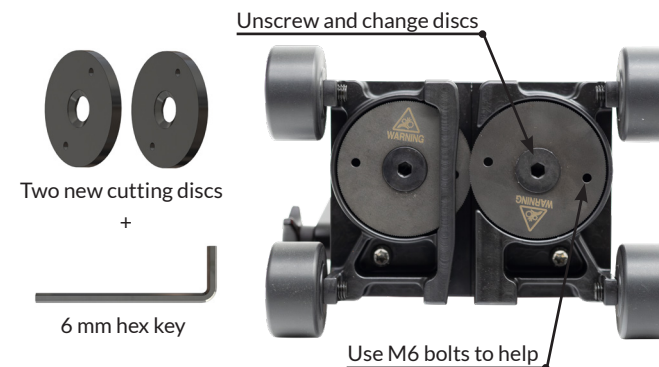

Important: Always make sure that the power source is removed from the cordless drill before doing care/maintenance operations!

MALCO FSXC2 CUTTER



Malco